

**Parts:**

Part no.	Description	Qty
JPC 1547	adhesive pad	4
ADU 9177	cable tie assy.	2
PHD 10016	hose - air inlet (if required)	1

**Claims:**

Complaint code: 2F2K

Time allowed: 0.35 hrs

S.R.O. 19.10.88.26

**Item 91****SUMP DAMAGE****DERIVATIVE:** 2.0 Diesel**Problem:**

Sump damage

**Cause:**

Insufficient ground clearance under abnormal road conditions

**Action:**

In the event of customer complaint, 2 skid plates, heavy duty springs and bump stop packers should be fitted as follows:

**Action:****SKID PLATE KIT**

- 1 View front subframe from the underside and locate the 2 existing large holes, one either side of the subframe. See 'A' in fig. 1.
- 2 To locate the skids, two smaller 11mm holes on each side of the subframe are also required, one in front of the large hole and one behind. See 'B' in fig. 1. One of these holes already exists on each side and the other must be drilled in position shown in fig. 1.
- 3 Insert screw 'C' through hole in skid plate 'D' and partially into tapped plate 'E' (as fig. 2).
- 4 Slide tapped plate into large hole in underside of subframe.

- 5 Position assembly such that skid plate pegs fit in 11mm locating holes in subframe and plate is in line with centre line of vehicle (as fig. 3).

- 6 Tighten screws to 18-20 Nm.

**BUMP STOP PACKERS AND SPRINGS**

- 7 Remove and dismantle both front spring and strut assemblies (see repair manual).

**SALOONS AND ESTATES**

- 8 Fit bump stop packer 'F' to both struts as shown in fig. 4

**SALOONS ONLY**

- 9 Replace existing spring with new spring NAM 5554 (Red/Green colour code) and reassemble.

**Note:**

The bump stop packers and revised springs (saloon only) will be introduced on production within the next few weeks. The skids will not be introduced on production.

**Claims:**

For fitting skid plates kit, bump stop, spring use S.R.O. 60.30.88-26

Time allowed: 1.70 hrs

Use complaint code: 1N1X

**Parts:**

NAM 5554 Spring (saloon only) 2 off  
 NAM 7676 Bump stop packer 2 off  
 KRF 10003 Skid plate kit 1 off (contains 2 skids)

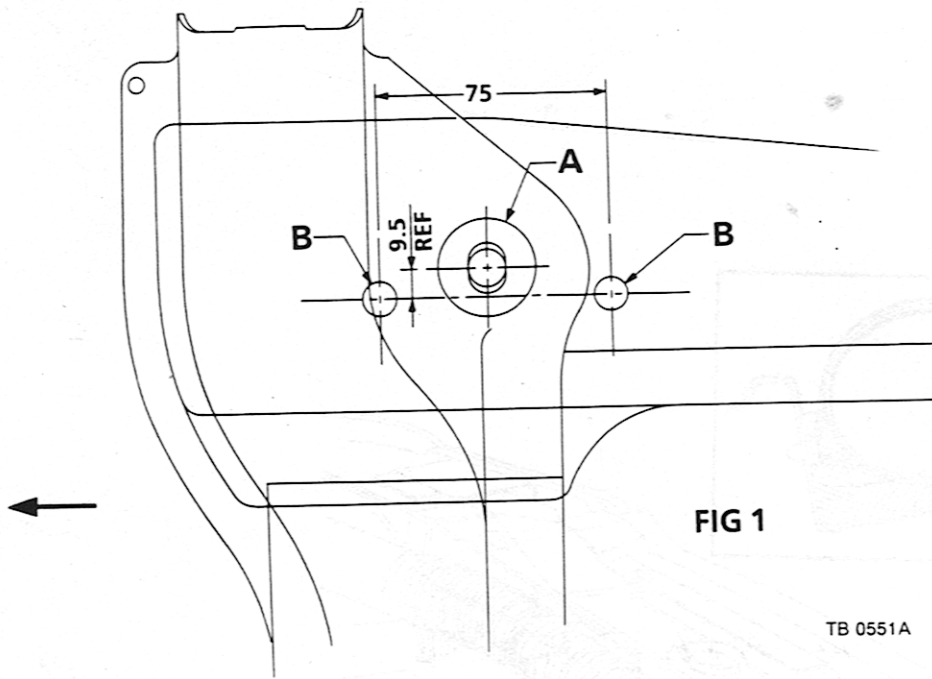

FIG 1

TB 0551A

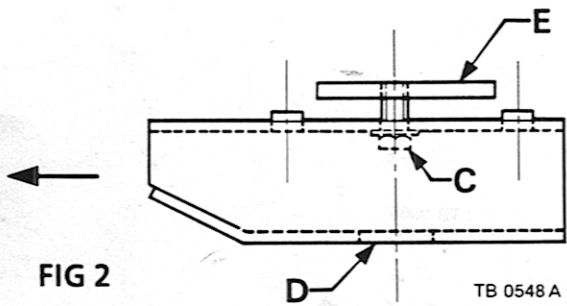

FIG 2

TB 0548 A

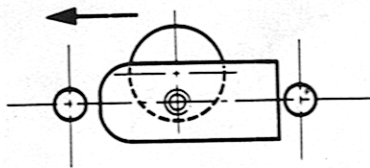

FIG 3

TB 0550 A

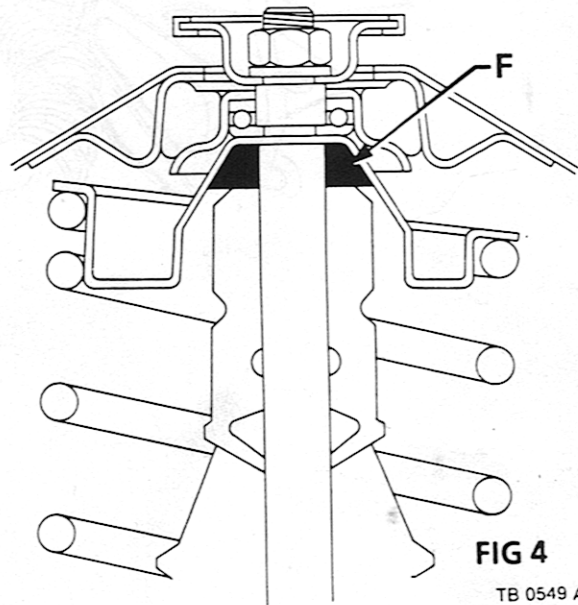

FIG 4

TB 0549 A